

# TS500-1800

<Sublimation transfer model> High-speed inkjet printer

Capabilities supported by assured technology add value to your business

## Low cost

Offers low-priced ink and ensures stable printing

### Ink degassing module

A degassing process is required for manufacturing conventional pouched ink. An embedded degassing module "MDM-20"\* enables TS500-1800 to use undegassed bottled inks. Low-priced inks are provided by eliminating the degassing process. Before the ink reaches the print head, gasses or bubbles inside the ink are eliminated, therefore stable ink jetting is assured.

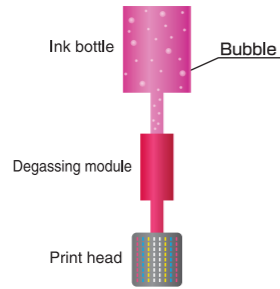

\* Degassing module needs to be replaced regularly.

## Software

### ■ Bundled RIP software

User friendly RIP "RasterLink 6" comes standard

# RasterLink 6

- ◆ More beautiful and advanced print results are achieved by following a user-friendly interface that is easy to operate.
- ◆ Color replacement function enhances the ability to re-create printed images.
- ◆ Print color can be simulated on Illustrator / Photoshop without an actual print
- \* This function requires MPM2 (Mimaki Profile Master 2).

<Supports Web update function>

- ◆ Program update and profile download can be easily performed via internet.

### ■ Specifications

Item	TS500-1800
Head	On-demand Piezo head (6 printheads with 3 staggered configuration)
Maximum width	1,890 mm (74.4")
Print resolution	300,450,600,900,1200dpi
Print mode	4 color (Uni-/ Bi-directional) 300x300dpi, 300x300HQ, 300x450HQ, 600x600dpi, 600x900dpi, 600x1200dpi 6 color (Uni-/ Bi-directional) 300x300dpi, 300x300HQ, 300x450dpi, 600x600dpi, 600x900dpi, 600x1200dpi
Ink	Sublimation Ink Sb300 Ink supply system
Media	Type Width Thickness Weight Print aspect Roll diameter Cutter
Drying device	Y-direction cutter after head section 3 way intelligent heater (Pre/Print/Post) External drying heater (Optional)
Media Take-up device	Roll take-up device, inside / outside selectable / 3 inch paper core
Print gap	1.5 mm~7.0 mm (Automatic adjustment)
Interface	USB2.0
Applicable standard	VCCI class A, FCC class A, UL60950-1, RoHS directive CE Marking (EMC, Low voltage and Machinery directive), CB Report
Power specification	Single-phase AC 200~240 V, 20 A or under
Power consumption	Less than 4,800W
Operational Temperature	20°C-30°C (64-86 °F)
Humidity	35-65 % RH (non condensing)
Dimensions (WxDxH)	3,810x1,400x1,700 mm (150.0"x55.1"x66.9") (*1)
Weight	750kg (1,653lbs)

\*1 Ink supply unit is not included in the dimensions

## High resolution

Newly developed sublimation ink Sb300

New sublimation ink ,Sb300, dries fast and reproduces deep and vibrant colors. Combined use of TS500-1800 and Sb300 delivers more impressive print results.



### ■ Optional

Professional software RIP for multi color separation

# Software RIP for Multi Color Separation TxLink 3

- ◆ Spot color can be assigned to each color on separation plates.
- ◆ ICC profile creation from CMYK + spot colors.
- ◆ Color replacement on raster data
- ◆ A variety of paneling functions, including step-and-repeat layout, which are useful for textile designing.

Lite, Standard and Professional editions are available.

### ■ Supplies

Item	Item No.	Remarks
Sublimation Ink Sb300	Blue	SB300-BL-BB
	Magenta	SB300-M-BB
	Yellow	SB300-Y-BB
	Black	SB300-KT-BB
	Light Blue	SB300-LBL-BB
	Light Magenta	SB300-LM-BB
Flushing liquid 03	FL003-Z-BB	2L bottle
Maintenance kit	SPA-0188	SPA-0189, 0190, goggles and clean stick 10 pcs
Head filter replacement kit	SPA-0189	HF filter 20 pcs
Mist absorption and exhaust fan filter	SPA-0190	Fan filter 30 sheets
Wiper replacement kit	SPA-0193	Wiper rubber 2 pc
Cap rubber replacement kit	SPA-0194	Cap rubber 6 pcs
Air filter replacement kit	SPA-0195	Filter element 2 pcs
Ink filter replacement kit	SPA-0196	
Waste ink tank SL	SPA-0197	1 pc
Clean stick for head surrounding	SPC-0527	50 pcs
Washing bypass jig kit assy	OPT-J0320	1 set



Our factory is certified according to ISO14001:2004

●Some of the samples in this catalogue are artificial renderings. ●Specifications, design and dimensions stated in this catalogue may be subject to change without notice (for technical improvements, etc.). ●The corporate names and merchandise names written on this catalogue are the trademark or registered trademark of the respective corporations. ●Inkjet printers print using extremely fine dots, so colors may vary slightly after replacement of the printing heads. Also note that if using multiple printer units, colors could vary slightly from one unit to other unit due to slight individual differences.

**Mimaki** MIMAKI ENGINEERING CO., LTD.  
2182-3 Shigeno-otsu, Tomi-city, Nagano 389-0512, Japan  
Tel: +81-268-64-2281

### Mimaki Global Network

USA	MIMAKI USA, INC.	Europe	MIMAKI EUROPE B.V.
Brazil	MIMAKI BRASIL COMERCIO E IMPORTACAO LTDA	Indonesia	PT. MIMAKI INDONESIA
India	MIMAKI INDIA PRIVATE LIMITED	Australia	MIMAKI AUSTRALIA PTY. LTD.
Taiwan	MIMAKI ENGINEERING (TAIWAN) CO.,LTD.	China	SHANGHAI MIMAKI TRADING CO.,LTD.
Singapore	MIMAKI SINGAPORE PTE. LTD.		

DB30271-02

# TS500-1800

<Sublimation transfer model> High-speed inkjet printer

**Mimaki**



# Massive Productivity Reliable stability

Capabilities supported by assured technology add value to your business





# Massive Productivity Reliable Stability

## TS500-1800

<Sublimation transfer model> High-speed inkjet printer



Not only is the TS500-1800 \*the worlds fastest sublimation printer, it also has many features that ensure reliably stable print operation. Please try unparalleled productivity supported by uninterrupted operation.

\* As of July 2013, according to a survey result by Mimaki Engineering Co.,Ltd.

Achieves the world's fastest\* 150 m<sup>2</sup>/h

### Six newly developed print heads

Six units of newly developed print heads are mounted.

The print heads are arranged in 3 staggered rows. Such a configuration enables a large print swath, compared with conventional models, and achieves a print speed of up to 150 m<sup>2</sup>/h.

Moreover, a variable dot function delivers fine, high resolution prints that are less granular by jetting two different ink drop sizes at a time.

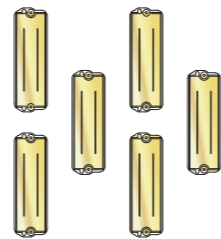

3 staggered rows

\*As of July 2013, according to a survey result by Mimaki Engineering Co.,Ltd. Surveyed print speeds are limited to sublimation transfer models. (300x300 to HQ,2P,Bi/Nr)

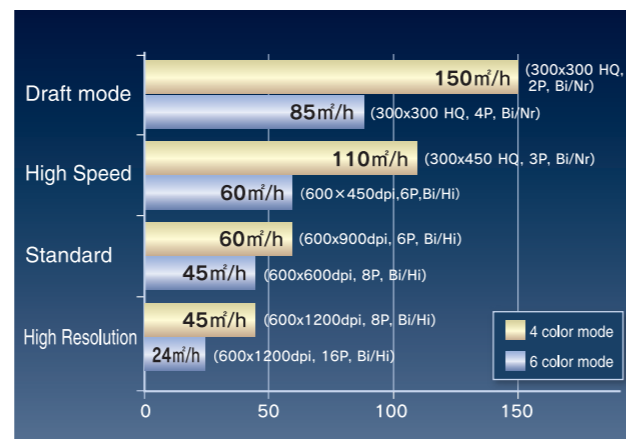
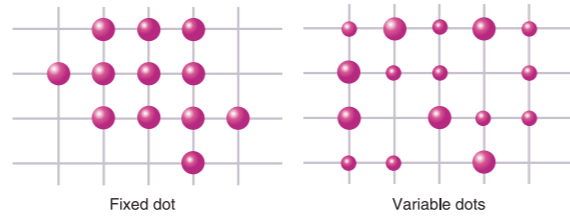

### Ensure feeding /take-up of heavy media

#### AMF mechanism

Mimaki's unique media feeding/take-up mechanism, AMF, delivers stable continuous printing of long and heavy rolled media and less banding by maintaining an appropriate tension depending on media. Maximum loadable media size is up to 60kg and 300mm in diameter.

\*AMF=Auto Media Feeder

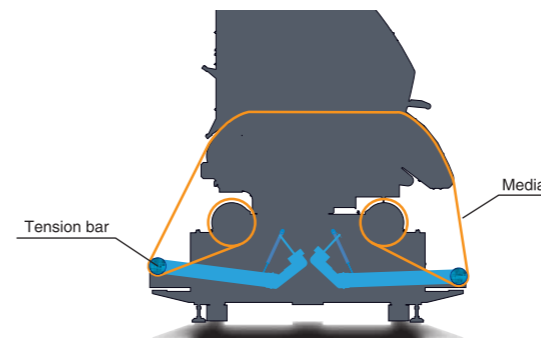

### Prevent the interruption of print caused by ink end

#### UISS (Uninterrupted Ink Supply System)

Mimaki's UISS (Uninterrupted Ink Supply System) will automatically switch whenever one ink container is empty to the other ink container of the same color. In addition, operators can exchange the ink containers even when the printer is at work. Therefore UISS enables long continuous print runs.

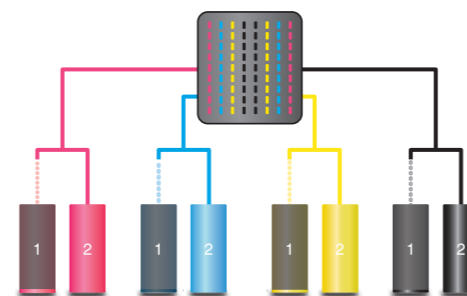

When bottle 1 is empty, the other bottle starts to supply ink.

### Drying mechanism for varied media

#### Optimized heater control

A print heater and two post heaters are provided. Built-in heaters accelerate the ink drying time by heating the media during and after printing. There are two post-heaters. The heater near the platen has a temperature controller in order to meet optimized temperatures of each media. The temperature can be increased to shorten ink drying time or decreased for heat-sensitive media.

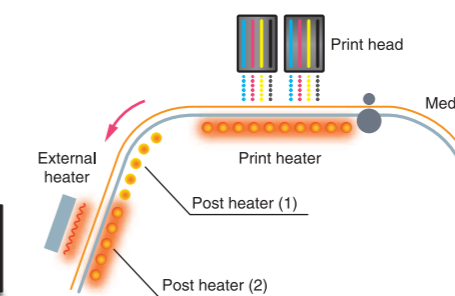

\* Depending on the environment, an external heater may be required.

### Support smooth operation

#### Ink mist reduction function

Embedded intake/exhaust fans create airflow which forces ink mists through filters. The reduction of these troublesome ink mists allows for stable operation of the machine.

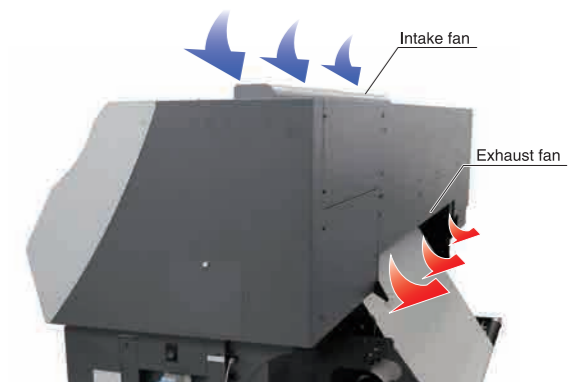

### Maintain print operation

#### Nozzle Recovery Function

Even if nozzle washing has no effect on a troubled nozzle, the print image quality can be restored immediately. During this nozzle downtime, the nozzle recovery function enables the printer to produce high quality prints continuously, without slowing down.

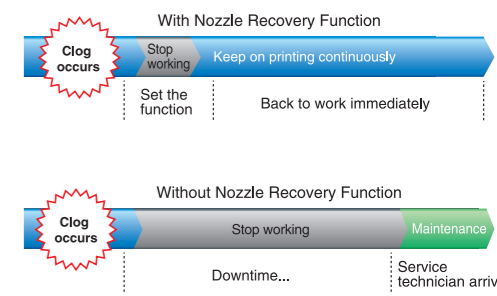

\* Nozzle Recovery Function is a temporary "failure averting function" to continue operation, and its recoverability is limited.

# TS500-1800